

~~Matrix Interpretations~~ N-weighted Finite Automata with Polyhedral Constraints

Johannes Waldmann (HTWK Leipzig)

June 23, 2015

Automated Analysis of Termination and Complexity

- ▶ ... for the computation model of (term or string) *rewriting*
- ▶ applications: (first order) functional programs, RNA transformations
- ▶ we use $(\mathbb{N}, +, \cdot)$ -weighted automata, defines an evaluation algebra over $\mathbb{N}^{Q(A)}$
- ▶ determine transitions (weights) of automaton by solving a constraint system
- ▶ *new feature: restrict the domain to $D \subset \mathbb{N}^{Q(A)}$*

String Rewriting

- ▶ alphabet Σ , set of rules $R \subseteq \Sigma^* \times \Sigma^*$,
- ▶ defines relation (one-step R -rewriting) $u \rightarrow_R v$
 $\iff \exists (l, r) \in R, p, q \in \Sigma^* : u = plq \wedge prq = v.$
- ▶ R is syntax (program),
 \rightarrow_R^* is semantics (computation)
- ▶ examples: $R_{\text{bubble sort}} = \{ba \rightarrow ab\}$,
 $R_{\text{exponentiation}} = \{ab \rightarrow baa\}$, $R_{?} = \{aa \rightarrow aba\}$
- ▶ related: semi-Thue-systems, Markov algorithms, Turing machines, formal grammars

Termination, and How to Prove It

- ▶ Def: R is strongly normalizing (or: (uniformly) terminating), written $\text{SN}(R)$ iff there is no infinite \rightarrow_R -chain.
- ▶ Examples: $\text{SN}(\{ab \rightarrow ba\})$, $\neg \text{SN}(\{ab \rightarrow b^2 a^2\})$
- ▶ SN is undecidable (cf. TM halting problem)

methods to prove termination

- ▶ syntactical (e.g., consider overlaps between parts of rules)
- ▶ (this talk) *semantical* (assign some meaning to the objects that are being rewritten)

Goal: *automate* the methods (and their *certification*)

Automated Termination Analysis

Why? Want tools that help in . . .

- ▶ analysis of source/machine code (in IDE/in OS)
- ▶ completion of equational specifications
- ▶ theorem proving (check that induction is well-founded)

How to measure progress? Compete!

- ▶ annual Termination Competitions
http://termination-portal.org/wiki/Termination_Competition_2015
- ▶ termination provers run on benchmarks (last year, $2.7 \cdot 10^4$ “job pairs”, $4 \cdot 10^6$ seconds CPU)

Interpretations

- ▶ Def: partial order $(D, >)$ is *well-founded*:
has no infinite $>$ -chains
- ▶ Def: interpretation $i : \Sigma^* \rightarrow (D, >)$ is *compatible*
with rewrite system R if $u \rightarrow_R v \Rightarrow i(u) > i(v)$.
- ▶ R admits compatible interpretation into some wf
domain $\iff \text{SN}(R)$
- ▶ note: “ \Leftarrow ” is trivial, take $i = \text{id}$ and $D = (\Sigma^*, \rightarrow_R^+)$
- ▶ example: for $R_{\text{bubblesort}} = \{ba \rightarrow ab\}$, count
inversions: $i(w) = |\{(j, k) \mid j < k \wedge w_j > w_k\}|$
then $u \rightarrow_R v \Rightarrow i(u) - 1 = i(v)$
- ▶ example: for $\{aa \rightarrow aba\} \dots ?$

Monotone Algebras

Σ -algebra A on wf $(D, >)$

- ▶ $\epsilon_A \in D$, and for each $f \in \Sigma$, a function $f_A : D \rightarrow D$
- ▶ A defines an interpretation $i_A : \Sigma^* \rightarrow D$
- ▶ Def: A is *monotone* iff
$$\forall f \in \Sigma : \forall x, y \in D : x > y \Rightarrow f_A(x) > f_A(y)$$
- ▶ Def: A is *compatible with R* if
$$\forall (l, r) \in R, \forall x \in D : l_A(x) > r_A(x).$$
- ▶ Thm: R admits a compatible monotone algebra over a well-founded domain $\iff \text{SN}(R)$.
note: “ \Leftarrow ” is still trivial
- ▶ “number of inversions” is not an algebra (over \mathbb{N})

Linear Algebra

domain $(\mathbb{N}^d, >)$

- ▶ with $\vec{x} > \vec{y} := x_1 > y_1 \wedge x_2 \geq y_2 \wedge \dots \wedge x_d \geq y_d$
is well-founded

example: 1st comp. counts number of aa factors:

$$[a](x_1, x_2) = (x_1 + x_2, 1), [b](x_1, x_2) = (x_1, 0)$$

- ▶ is monotone:
all coeffs. ≥ 0 , coeff. of x_1 in 1st comp. is > 0
- ▶ is compatible with $R = \{aa \rightarrow aba\}$:
 $[aa](x_1, x_2) = (x_1 + x_2 + \boxed{1}, 1)$,
 $[aba](x_1, x_2) = (x_1 + x_2, 0)$

this algebra is the algebra of a weighted automaton

Algebras of Weighted Automata

- ▶ D -weighted FA A
 - ▶ alphabet Σ , states Q
 - ▶ initial weight vector $I : D^Q$
 - ▶ transitions $T : \Sigma \rightarrow D^{Q \times Q}$
 - ▶ final weight vector $F : D^Q$
- ▶ its weight function: $A : \Sigma^* \rightarrow D : w \mapsto F \cdot T(w) \cdot I$
- ▶ its algebra (with carrier D^Q): given by T and I
- ▶ D could be any semiring (because we need properties of matrix multiplication)
- ▶ here, we restrict to $D = (\mathbb{N}, +, \cdot, 0, 1)$,
 I picks the initial state, F picks the final state

Algebras from Automata, Example

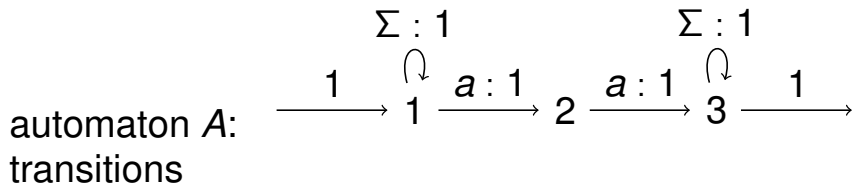

$$T(a) = \begin{pmatrix} \boxed{1} & 1 & 0 \\ 0 & 0 & 1 \\ 0 & 0 & \boxed{1} \end{pmatrix}, T(b) = \begin{pmatrix} \boxed{1} & 0 & 0 \\ 0 & 0 & 0 \\ 0 & 0 & \boxed{1} \end{pmatrix},$$

compute

$$T(aa) = \begin{pmatrix} 1 & 1 & \boxed{1} \\ 0 & 0 & 1 \\ 0 & 0 & 1 \end{pmatrix} > \begin{pmatrix} 1 & 1 & \boxed{0} \\ 0 & 0 & 1 \\ 0 & 0 & 1 \end{pmatrix} = T(aba)$$

WFA and Rewriting

goal: the algebra of a WFA A is well-founded, monotone, and compatible with R

$\Rightarrow A$ is a certificate of termination of R

- ▶ wf: use domain $(\mathbb{N}^d, >)$ as defined earlier
- ▶ monotone (on the left): for each a , $T(a)_{1,1} \geq 1$
- ▶ compatible with R :
 $T(l)_{1,d} > T(r)_{1,d}$,
and for each $(l, r) \in R$: $T(l) \geq T(r)$ (point-wise),
and monotone on the right: $T(a)_{d,d} \geq 1$.

From Strings to Terms

- ▶ interpret k -ary letter f by
$$f_A : (\vec{x}_1, \dots, \vec{x}_k) \mapsto \vec{F}_0 + \sum_i F_i \cdot \vec{x}_i$$
where F_0 is vector, F_1, \dots are square matrices,
- ▶ this is a restricted form of multi-linear functions, closed w.r.t. composition (needed for interpretation of terms with variables)
- ▶ $\forall i \geq 1 : (F_i)_{11} \geq 1$ implies *monotonicity*,
- ▶ for rule $l \rightarrow r$, compute
$$[l](\vec{x}_1, \dots) = L_0 + \sum_i L_i \cdot \vec{x}_i, [r](\vec{x}_1, \dots) = R_0 + \dots$$
then $\forall i \geq 0 : L_i \geq R_i$ (component-wise)and $(L_0)_1 > (R_0)_1$ implies *compatibility*

From Strings to Terms ... and Back

- ▶ for 1-ary, this means $f_A(\vec{x}) = F_0 + F_1\vec{x}$
equivalently, $f_A \begin{pmatrix} \vec{x} \\ 1 \end{pmatrix} = \begin{pmatrix} F_1 & F_0 \\ 0 \dots 0 & 1 \end{pmatrix} \cdot \begin{pmatrix} \vec{x} \\ 1 \end{pmatrix}$
- ▶ previous interpretation (automaton)

$$[\]_A : a \mapsto \begin{pmatrix} \boxed{1} & 1 & 0 \\ 0 & 0 & 1 \\ 0 & 0 & \boxed{1} \end{pmatrix}, b \mapsto \begin{pmatrix} \boxed{1} & 0 & 0 \\ 0 & 0 & 0 \\ 0 & 0 & \boxed{1} \end{pmatrix},$$

will be written

$$[a]_A(\vec{x}) = \begin{pmatrix} 0 \\ 1 \end{pmatrix} + \begin{pmatrix} 1 & 1 \\ 0 & 0 \end{pmatrix} \vec{x},$$

$$[b]_A(\vec{x}) = \begin{pmatrix} 0 \\ 0 \end{pmatrix} + \begin{pmatrix} 1 & 0 \\ 0 & 0 \end{pmatrix} \vec{x}$$

Constraints for Unknown Automata

- ▶ “monotone, and compatible with R ”
is a *constraint system* for the transition matrices
- ▶ e.g., from $R = \{ba \rightarrow ab\}$ with
 $[a](x) = a_0 + a_1x$, $[b](x) = b_0 + b_1x$ obtain $a_0 \geq 0$, $a_1 \geq 1$, $b_0 \geq 0$, $b_1 \geq 1$, $b_1a_0 + b_0 > a_1b_0 + a_0$
- ▶ write constraint system in suitable form

```
(declare-fun P () Int) (declare-fun Q () Int)
(declare-fun R () Int) (declare-fun S () Int)
(assert (and (< 0 P) (<= 0 Q) (< 0 R) (<= 0 S)
(assert (> (+ (* P S) Q) (+ (* R Q) S))))
```

constraint solver searches satisfying assignment
- ▶ this is (now) a standard method in automated termination

Matrix Interpretation Success Story

Termination of $\{a^2 \rightarrow bc, b^2 \rightarrow ac, c^2 \rightarrow ab\}$
follows from this automaton:

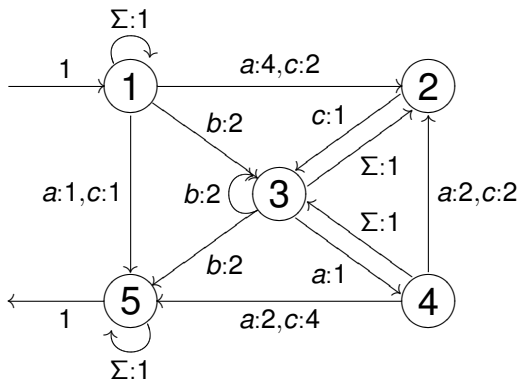

(Hofbauer, Waldmann, 2006)

Polyhedral Domains

(this is the point of the RTA'15 paper)

- ▶ standard method uses domain $(\mathbb{N}^d, >)$,
now restrict to some subset $D \subset \mathbb{N}^d$
defined by a conjunction of linear inequalities
- ▶ D contains the weight vectors reachable by A
- ▶ behaviour of transitions of A outside D is ignored
- ▶ relaxed proof obligations for compatibility
 $\forall x \in D : [l](x) > [r](x)$
- ▶ additional proof obligations
 $D \neq \emptyset, \forall a \in \Sigma : [a](D) \subseteq D$
- ▶ get *more* and *different* termination proofs

Polyhedral Constraints, Example

Prove termination of $R = \{fg \rightarrow ff, gf \rightarrow gg\}$.

Use domain $D = \{(x_1, x_2, x_3) \in \mathbb{N}^3 \mid x_3 \geq x_2 + 1\}$.

$$[f](x_1, x_2, x_3) = (x_1 + 2x_2 + 1, 0, x_3 + 1)$$

$$[g](x_1, x_2, x_3) = (x_1, x_2 + 1, x_3 + 1)$$

$$[fg](x) = (x_1 + 2x_2 + 1, 0, x_3 + 2),$$

$$[ff](x) = (x_1 + 2x_2 + 2, 0, x_3 + 2).$$

Now $\forall x \in D : [fg](x) > [ff](x)$, despite $\boxed{2}$.

$$x_1 + 2x_3 + 1 \geq x_1 + (2x_2 + \boxed{2}) + \boxed{1} > x_1 + 2x_2 + 2$$

Interpret. with Polyhedral Constraints

A polyhedrally constrained matrix interpret. contains:

- ▶ the interpretation, $f_A(x_1, \dots) = F_0 + \sum F_i x_i$
- ▶ the domain, given by $C_A \in \mathbb{Q}^{c \times d}$, $B_A \in \mathbb{Q}^{c \times 1}$,
as $D = \{x \mid x \geq 0, Cx + B \geq 0\} \subseteq \mathbb{N}^d$

In the example, $d = 3$, $c = 1$, $C = (0, -1, 1)$, $B = -1$.

to use it for termination of rewriting, we show:

- ▶ domain is non-empty,
- ▶ interpretation respects the domain,
- ▶ interpretation is compatible with rules.

for each of these, we use *certificates*

Polyhedral Constraints: Domains

Def: A respects the domain if $f_A : D^k \rightarrow D$.

This is certified by giving

- ▶ for each letter f , with interpretation

$$f_A(x_1, \dots) = F_0 + \sum F_i x_i,$$

- ▶ matrices $W_1, \dots, W_k \in \mathbb{Q}_{\geq 0}^{c \times c}$ with

$$CF_0 + B \geq (\sum_i W_i)B,$$

$$\forall 1 \leq i \leq k : CF_i \geq W_i C$$

example: $D = \{(x_1, x_2, x_3) \in \mathbb{N}^3 \mid x_3 \geq x_2 + 1\}$,

$[f](x_1, x_2, x_3) = (x_1 + 2x_2 + 1, 0, x_3 + 1)$

take $W_1 = 0$

Polyhedral Constraints: Compatibility

Compatibility of A w.r.t. rule $(l \rightarrow r)$

with $|\text{Var}(l) \cup \text{Var}(r)| = k$

where $([l]_A - [r]_A)(x_1, \dots, x_k) = \Delta_0 + \sum_i \Delta_i x_i$,

is certified by matrices $U_1, \dots, U_k \in \mathbb{Q}_+^{d \times c}$,
such that $\forall i : \Delta_i \geq U_i C$ and $\Delta_0 > \sum_i U_i B$

example: $D = \{\vec{x} \in \mathbb{N}^3 \mid -x_2 + x_3 - 1 \geq 0\}$,

$[f](\vec{x}) = (x_1 + 2x_2 + 1, 0, x_3 + 1)$,

$[g](\vec{x}) = (x_1, x_3, x_3 + 1)$,

$[fg - ff](\vec{x}) = (-2x_2 + 2x_3 - 1, 0, 0)$

take $U_1 = (2, 0, 0)^T$.

Polyhedral Constraints: Combined

to prove termination of rewriting system R ,
determine

- ▶ matrix interpretation (weighted automaton)
- ▶ polyhedral domain (linear inequalities)

as solution of a constraint system for validity of
certificates for

- ▶ non-emptiness of the domain
- ▶ respecting the domain
- ▶ compatibility with rules

implemented in termination prover Matchbox2015.

Completeness of Certificates

Thm: automaton respects domain, is R -compatible
 \iff certificates exist.

- ▶ Correctness (“ \Leftarrow ”) is easily verified.
- ▶ Completeness (“ \Rightarrow ”) follows from (inhomogenous) Farkas’ Lemma.

The Lemma (in one of many versions) says

- ▶ A linear inequality I is implied by a system S of linear inequalities
- ▶ $\iff I \geq$ some positive linear combination of S .

Derivational Complexity

- ▶ motivation: (automated) analysis of complexity of programs
- ▶ derivation height of a term, w.r.t. \rightarrow :
$$\text{dh}(\rightarrow, s) = \sup\{k \mid \exists t : s \rightarrow^k t\}$$
- ▶ derivational complexity of \rightarrow :
$$\text{dc}(\rightarrow) = n \mapsto \max\{\text{dh}(\rightarrow, s) \mid |s| \leq n\}$$
- ▶ example: $\text{dc}(\rightarrow_{\{ba \rightarrow ab\}}) \in \Theta(n \mapsto n^2)$
- ▶ “derivational complexity” is an (extra) category of Termination Competitions

Deriv. Complexity and Interpretations

- ▶ complexity of matrix interpretation
(using matrices from some set \mathcal{M})
$$\text{dc}(\mathcal{M}) = n \mapsto \max\{\|M\| : M \in \mathcal{M}^{\leq n}\}$$
- ▶ Thm: if \mathcal{M} is finite and *upper triangular*
(0 below main diagonal, 0 or 1 on main diag.),
then $\text{dc}(\mathcal{M})$ is polynomial
- ▶ polyhedral domain restriction is orthogonal to
this, but sometimes helpful
- ▶ ex. $R = \{fg \rightarrow ff, gf \rightarrow gg\}$: given automaton is
upper triangular, this proves $\text{dc}(R)$ quadratic,
this was known, but by different (more
complicated) method (root labelling)

Results, Discussion, **Announcement**

- ▶ main result: method is correct, implementation.
- ▶ auxiliary results, see paper
- ▶ challenge: improve implementation
(improve constraint solver, better bit-blasting)
- ▶ challenge: automated proof of quadratic derivational complexity of $\{a^2 \rightarrow cb, b^2 \rightarrow ca, c^2 \rightarrow ba\}$
- ▶ open: extend to other semirings, e.g., arctic.
- ▶ for more on rewriting and termination: ***8th Intl. School on Rewriting, Leipzig, August 10-14***
<http://nfa.imn.htwk-leipzig.de/ISR2015/>